

Evolve Security Products Limited

## PEDESTRIAN ENTRANCE CONTROL

### PG127 Paddle Gate

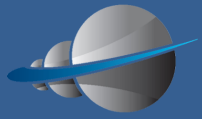



# SG127 Paddle Gate

## PG127 PADDLE GATE

The PG127 double leafed paddle gate provide safe, high speed, bi-directional pedestrian throughput, with an elegant and sophisticated look, essential for today's corporate environment.

### SECURITY

- 6 high level IR detection sensors are used to monitor user progression, security breaches and provide safety.
- Gap under obstacles can be monitored by 6 optional low level detection sensors.
- Various obstacle highs up to 1200mm.
- Standard obstacle material is 10mm thick plexiglass PMMA to reduce the risk of breakage from attacks with hammers.
- Electromechanical break to withstand forced entry attempts.

### SAFETY

- 6 high level detection sensors provide user protection;
- Low energy impact in the opening and closing cycle;
- Manual push in any direction, in the event of a power loss;
- Fire alarm input to automatically drive the obstacle open in either direction
- Various programable operating modes providing safety over security.

### AESTHETICS

- Transparent glass side walls;
- Minimal footprint.
- Discreet card reader integration.
- Clear plexiglass obstacles.
- Brushed stainless steel finish.

### THROUGHPUT

- 25-30 people per/min, depending on access control and users.
- User status pictograms.
- User functional pictograms.
- Stacking function 0-99.



### CONNECTIVITY

- Volt free relay inputs;
- TCP/IP communication;
- Reception touch screen controller;
- Reception push button consoles.

### RELIABILITY

- MCBF of 5 million cycles, with routine maintenance;
- Extended manufactures parts warranty for low cost of ownership.

## KEY FEATURES

1. Aesthetically and streamlined designed with fastest throughput.
2. Easy to Installation, maintain and service.
3. Open protocol: -
  - Onboard diagnostics, no PC required.
  - Free training for anyone wishing to work on its products (subject to T&C) .
  - End users are not tied to one service provider.
4. Security: -
  - Tailgate detection/alarm.
  - Loitering alarm.
  - Wrong direction of travel alarm.
  - Crawling alarm.
  - Obstacles made from 10mm plexiglass as standard.
5. Safety: -
  - 6 send and receive passage detection and safety sensors in the top rail.
  - 6 optional send and receive enhanced safety detection sensors in the bottom rail.
  - Force limiter.
  - Fire alarm input.
  - Power failure free movement.
6. Standard plexiglass obstacle height 870mm FFL
7. 10mm toughened glass side walls.
8. Standard card reader mounting brackets.
9. Status and functional indicators to advise users whether the lane is in use and whether is safe to pass.



10. Wheelchair / Bulky Item Accessibility - Designed to comply with most international disability regulations such as the UK DDA (Disability Discrimination Act) and the USA ADA (Americans with Disabilities Act) with clear walkway widths up to 900mm wide.
11. Fire Alarm Integration - Each master cabinet requires a separate normally open contact from the fire alarm panel, when activated the obstacle will automatically drive open.
12. Open Commands – Each controlled direction of travel requires a normally open volt free contact closing for not more than 1 second.
13. Hold Open - Each direction of travel can be held open using the open command. A normally closed volt free contact of more than 3 seconds is required to set the lane into hold open mode.
14. Operating Parameters – Twelve configurable operating parameters that can adjust the working mode of the lane and its level of security/safety.

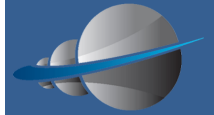

SG127



## OPTIONS

1. Security:-
  - Output relays to trigger CCTV, lock doors, or give transaction complete signals.
  - Glass heights up to 1.8m to prevent jumping over.
2. Safety:-
  - 6 low level detection sensors providing increase safety of large items, small children and increased security.
3. Obstacle Height - Standard options 1.2mt, other heights available from 870 to 1200mm on request.
4. Obstacle Width - Standard options 600mm and 900mm other widths available from 500mm to 900mm on request.
5. Free standing surface plinth to reduce civils' and speed installation;
6. Various cabinet colours.
7. Drilling templates for a speedy and more accurate installation.
8. Reception touch screen console and engraved push button console.
9. Safety signs.

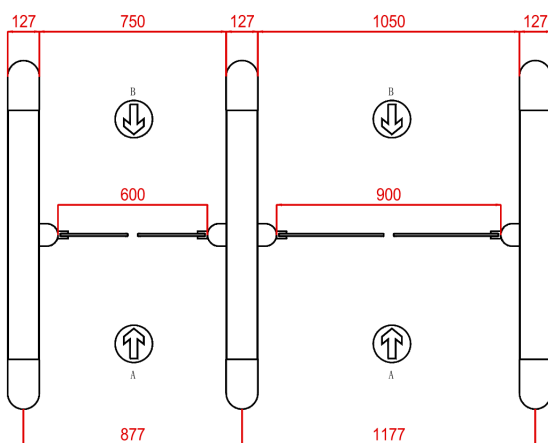
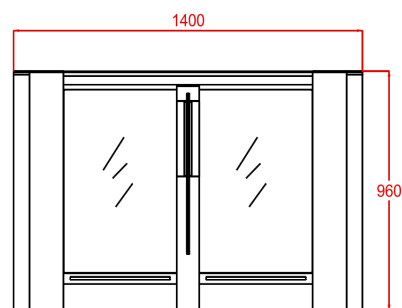
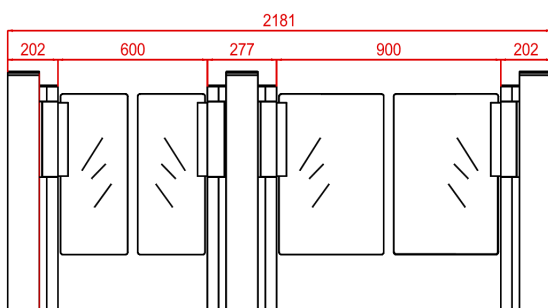

SG127



## ORDERING INFORMATION

### Each cabinet is supplied with:-

- 10mm Plexiglass PMMA arm H870mm.
- Cabinet L1400 x W202 x H980.
- 16 detection sensors.
- 12 months warranty.

SG127 L	W600 Double Leaf Walkway, L/H cabinet (Slave).	<a href="#">Data Sheet</a>
SG127 M	W600 Double Leaf Walkway, Middle cabinet (Master/Slave).	
SG127 R	W600 Double Leaf Walkway, R/H cabinet (Master).	
SG127 L	W900 Double Leaf Walkway, L/H cabinet (Slave).	<a href="#">Data Sheet</a>
SG127 M	W900 Double Leaf Walkway, Middle cabinet (Master/Slave).	
SG127 R	W900 Double Leaf Walkway, R/H cabinet (Master).	



Photos and information in this brochure are for reference only and may not reflect the actual product. Our brochures and product are subject to change without notice.

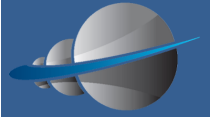

# SG127

# HOW TO CONTACT US



## UK Head Office

### **Evolve Security Products Ltd.**

Unit 4, Kenyons Yard,  
Weyhill Road,  
Andover,  
Hampshire.  
ENGLAND  
SP10 3NP

**t:** 0044 1264 334786

**e:** Sales@EvolveSecurityProducts.com

**w:** EvolveSecurityProducts.com

## HK Head Office

### **Evolve Autogate Products Ltd.**

Flat C,4/F  
Lladro Center,  
No., 72 Hoi Yuen Road,  
Kwun Tong,  
Kowloon.  
HONG KONG

**t:** 00852 35231568

**e:** info@Evolve-Autogate.com

**w:** Evolve-Autogate.com

**[Click Here For Full List of  
Global Contacts](#)**

**“Evolving the way you manage your pedestrian access.”**