



## PG127 W600

### DATA SHEET

#### DESCRIPTION

The PG127 is a double leaf obstacle gate with a 600mm wide walkway which can be used in conjunction with the PG127 W900.

It provides safe, high speed, bi-directional pedestrian throughput, with an elegant and sophisticated look, essential for today's corporate environment.

#### STANDARD FEATURES

1. Cabinet frame: Steel frame with RoHS anti-corrosion zinc plating treatment.
2. Cabinet outer: Brushed AISI 304L stainless steel, 220g.
3. Detection photocells: 6 transmit reflect detection sensors high level.
4. Main column: Containing the DC motor and gearbox, a geared electromagnetic brake for locking the obstacles in the event of forced entry.
5. Obstacle: Clear plexiglass PMMA arm 870mm high, 10mm thick.
6. Open Commands: Normally open volt free contacts, closing for not more than 1 second.
7. Hold open: Normally open volt free contacts, closing for more than 3 second.
8. Fire Input: Normally open volt free contacts, closing for more than 3 second.
9. Outputs: Three transistor outputs, two for passage complete or counters and one for fraud alarms.
10. Output: RS232 protocol.
11. Status and function pictograms: Indicating fraud, lane and passage status to the user.
12. Front access panel: Housing, TD controller, PSU and isolation switch.
13. Side walls: Clear 10 mm toughened glass.

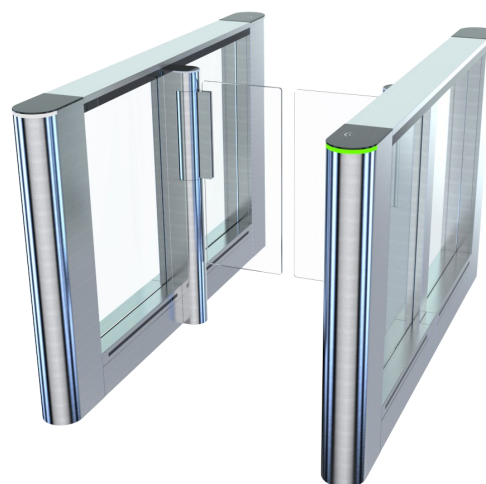

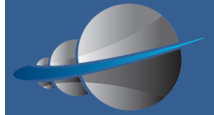

## CABINET TYPES

SG127 L

SG127 M

SG127 R

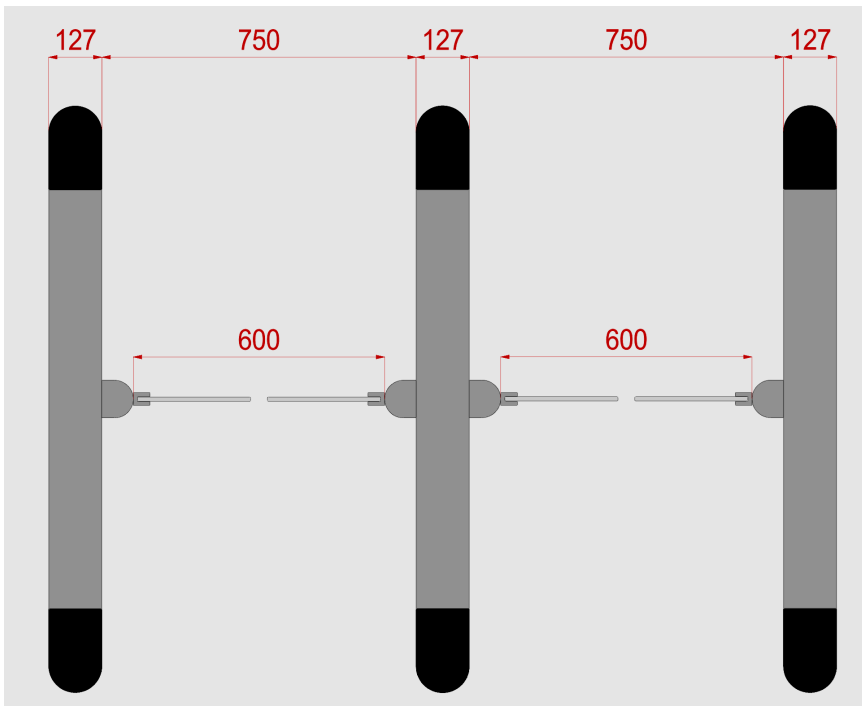

SG127 L = Slave Cabinet.

SG127 M = Master and Slave Cabinet.

SG127 R=Master Cabinet.

## USERS SAFETY

SAFE	CAUTION	CAUTION	CAUTION	CAUTION

DANGER	DANGER	DANGER	DANGER	DANGER	USE SG127 W900	USE PG303

If regular use by user types with the risk classification of caution or danger is anticipated, than we recommend that the optional detection sensors are fitted, all parameters are set to the optimum level of protection and additional safety signage may be required.

PG127 W600



## TECHNICAL CHARACTERISTICS

Electrical supply	Single phase 100-240 Vac (+/- 10%), 180W, 50/60Hz + Ground
Power consumption	Standby - 5W, Cycle - 35W, Peak - 40W
Motor and Gearbox	24Vdc motor with planetary gearbox.
Min opening or closing times	0.5s (Depending on access control reactivity and speed of the user)
Ambient operating Temperature	0 to +60 Deg C.
Ambient relative humidity in operation	5 to 95%, no condensation.
MTBF	5 Million cycles, with recommended maintenance.
Sound level	55dB from 1m away
Weight	62Kg (per Left/right unit), 91kg (per middle unit)
Warranty	12 months for date of supply—24 to 48 months extended parts warranty available at time of purchase, subject to
Conforms to:- CE, UKAC	

## OPTIONS

- Obstacles made from 8 mm thick toughened glass.
- Plexiglass heights: 1200mm.
- Toughened glass heights: 870 and 1200mm.
- Bespoke plexiglass or toughened glass heights and widths;
- 6 additional low level safety and security detection sensors;
- Bespoke brackets for internal or external reader and lift displays integration.
- Customised logo on obstacles self adhesive or laser etched.
- Surface plinths for marble floors or under floor heating.
- Drilling templates.
- Numerous heat treated cabinet colours.
- Reception control consoles.

PG127 W600

## DIMENSIONS

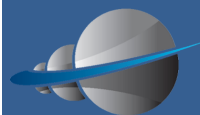
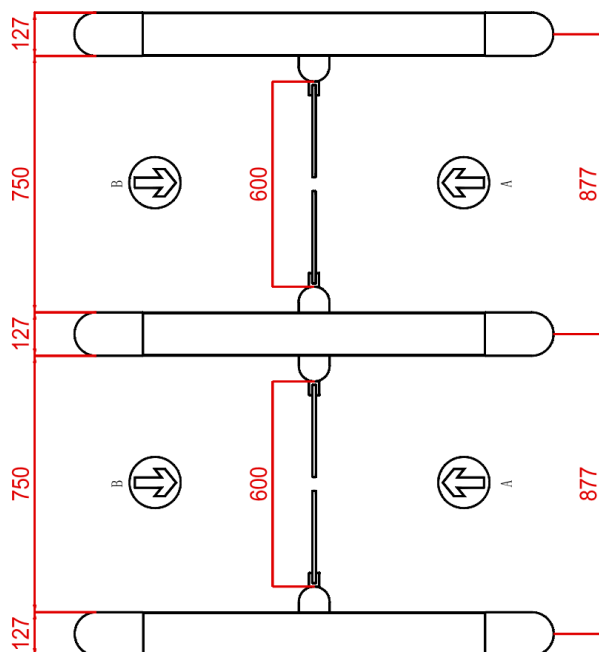
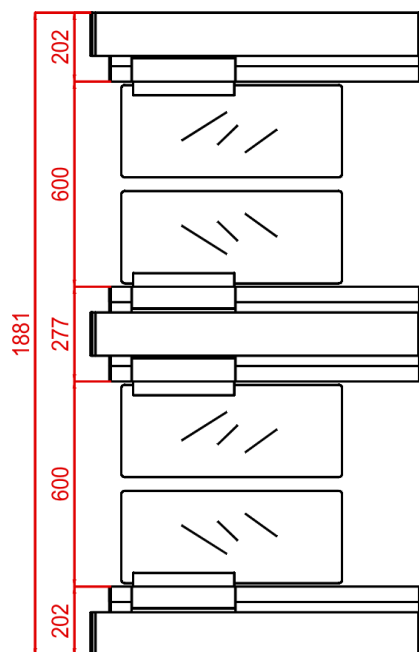
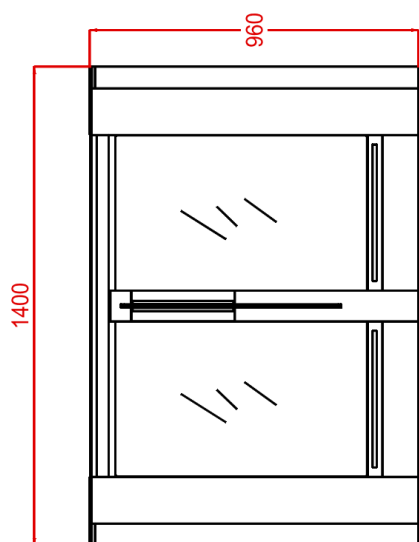

# PG127 W600

# HOW TO CONTACT US



## UK Head Office

### **Evolve Security Products Ltd.**

Unit 4, Kenyons Yard,  
Weyhill Road,  
Andover,  
Hampshire.  
ENGLAND  
SP10 3NP

**t:** 0044 1264 334786

**e:** Sales@EvolveSecurityProducts.com

**w:** EvolveSecurityProducts.com

## HK Head Office

### **Evolve Autogate Products Ltd.**

Flat C,4/F  
Lladro Center,  
No., 72 Hoi Yuen Road,  
Kwun Tong,  
Kowloon.  
HONG KONG

**t:** 00852 35231568

**e:** info@Evolve-Autogate.com

**w:** Evolve-Autogate.com

**[Click Here For Full List of  
Global Contacts](#)**

**“Evolving the way you manage your pedestrian access.”**